

PS-D-266-Air/1~500mW

SPECIFICATION

Model	PS-D-266-Air-A	PS-D-266-Air-B
Wavelength (nm)	266±1	
Output power (W)	1~100mW@1MHz	100mW~500mW@1MHz
Rep.rate (MHz)	1KHz~1MHz	
Pulse duration (ps)	~10	
Power stability (rms, over 4 hours)	<3%, <1%	
Peak-to-Peak stability (rms ,over 4 hours)	<2 %	
Transverse mode	TEM ₀₀	
Beam Circularity (%)	>90	
Beam quality (M ²)	<1.2	
Beam divergence, full angle (mrad)	<3	
Beam diameter at the aperture (1/e ² , mm)	~1	
Polarization ratio	>100:1, Horizontal	
Dimensions (mm ³)	370 (L) ×317 (W) ×132 (H)	On Request
Beam height from base plate (mm)	90.5	
Warm-up time (minutes)	<20	
Operating temperature (°C)	20~30	
Power supply	DC 24V/ 13A (optional)	



PICOSECOND PULSED LASER AT 266nm

Picosecond pulsed laser at 355nm is made features of short pulse duration, high repetition rate and good beam quality, which is used in glass marking, sapphire marking, ceramic cutting, semiconductor cutting, solar panels coating, film scribing, etc.



PS-D-266-Air *Integrated electronics*

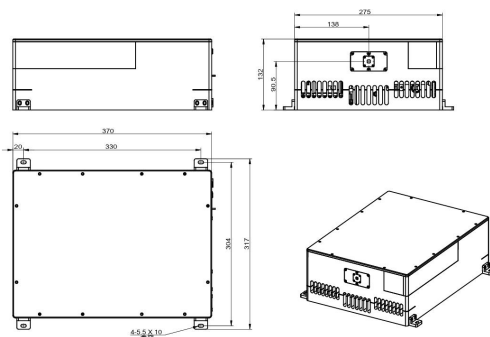

370 (L) ×317 (W) ×132 (H) mm³

Power supply 100-240VAC

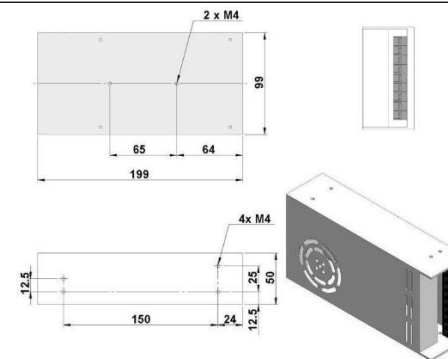

DC24V 13A; 199 (L) ×99 (W) ×50 (H) mm³, 1 kg