

Lms24PD-05 series

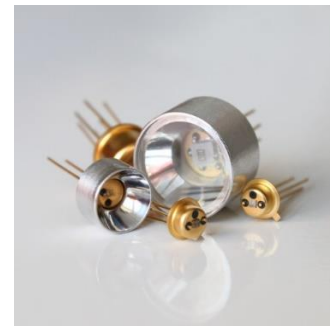

Device parameters	Symbol	Value	Units
Sensitive area diameter	d	0.5	mm
Storage temperature	T_{stg}	-50..+60*	$^{\circ}\text{C}$
Operating temperature	T_{opr}	-60..+90*	$^{\circ}\text{C}$
Reverse voltage	V_r	1.0	V

*Operating temperature for a PD with a built-in preamplifier is 0..+50 $^{\circ}\text{C}$

*PD design for higher storage/operating temperature is available under request

Photodiode parameters	Conditions	Symbol	Value	Units
Cut-off wavelength	$T = 25\text{ }^{\circ}\text{C}$	λ_{cut}	2.40 - 2.46	μm
Max. sensitivity range (>80%)	$T = 25\text{ }^{\circ}\text{C}$	λ_p	1.1 - 2.3	μm
Dark current	$T = 25\text{ }^{\circ}\text{C}; V_r = 1\text{ V}$	I_d	10 - 100	μA
Shunt resistance	$T = 25\text{ }^{\circ}\text{C}; V_r = 10\text{ mV}$	R_{sh}	4 - 18	$\text{k}\Omega$
Capacitance	$T = 25\text{ }^{\circ}\text{C}; \lambda = \lambda_p$	C	200 - 600	pF
Sensitivity	$T = 25\text{ }^{\circ}\text{C}; \lambda = \lambda_p$	S	0.9 - 1.1	A/W
Noise equivalent power	$T = 25\text{ }^{\circ}\text{C}; \lambda = \lambda_p$	NEP	$(0.9-2.0) \cdot 10^{-12}$	$\text{W}/\text{Hz}^{1/2}$
Detectivity	$T = 25\text{ }^{\circ}\text{C}; \lambda = \lambda_p$	D^*	$(2-5) \cdot 10^{10}$	$\text{cm}^2 \cdot \text{Hz}^{1/2} \cdot \text{W}^{-1}$

Photodiodes Lms24PD-05 series are fabricated from narrow band-gap GaInAsSb/AlGaAsSb-based heterostructures lattice matched to GaSb substrate.

All specifications are for photodiode operation at 25 $^{\circ}\text{C}$ unless otherwise stated

Typical spectral response

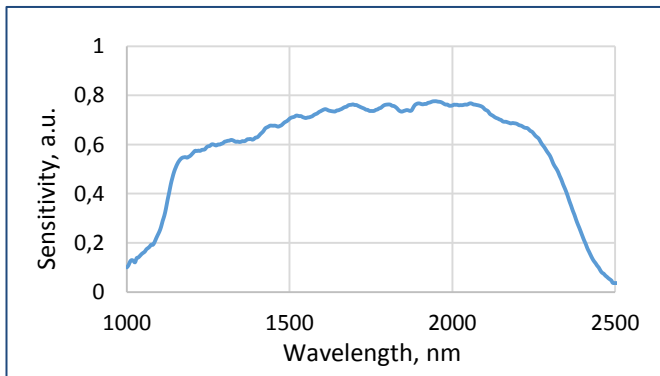

Temperature shift of spectral response

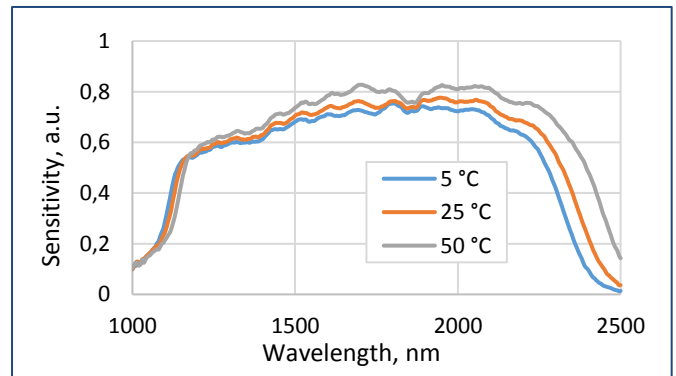

Typical current-voltage characteristic

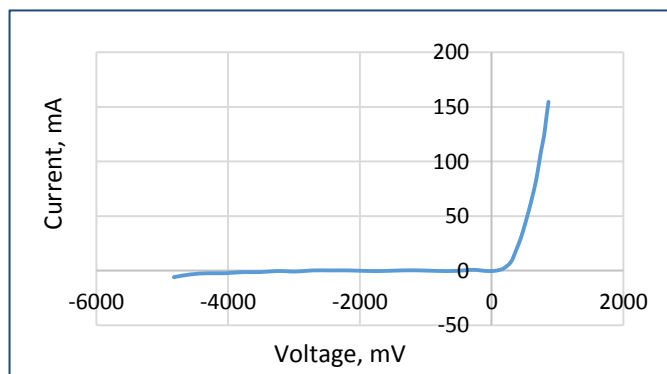

Capacitance vs. temperature

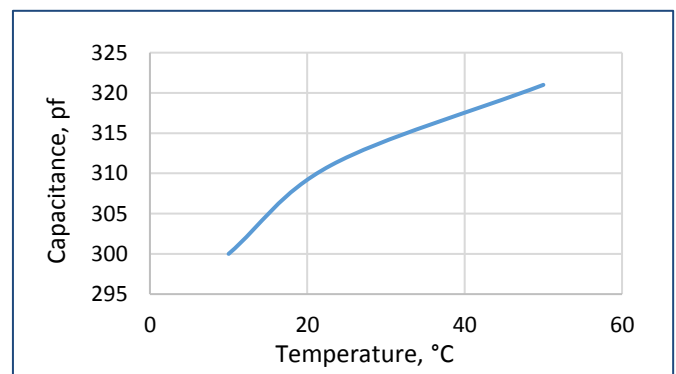

Packages	Model
TO-18 with a cap without a glass window	Lms24PD-05
TO-18 with a parabolic reflector without a glass window	Lms24PD-05-R
TO-18 with a parabolic reflector with a glass window	Lms24PD-05-RW
TO-5 with a built-in thermocooler and thermoresistor, covered by a cap with a glass window	Lms24PD-05-TEM
TO-5 with a built-in thermocooler and thermoresistor, covered by a parabolic reflector with a glass window	Lms24PD-05-TEM-R
PD with a built-in preamplifier; TO-18 with a parabolic reflector without a window in an aluminum tube	Lms24PD-05-R-PA
PD with a built-in preamplifier; TO-18 with a parabolic reflector with a window in an aluminum tube	Lms24PD-05-RW-PA

Recommended modes of PD operation

PD used as a current source (photovoltaic mode)

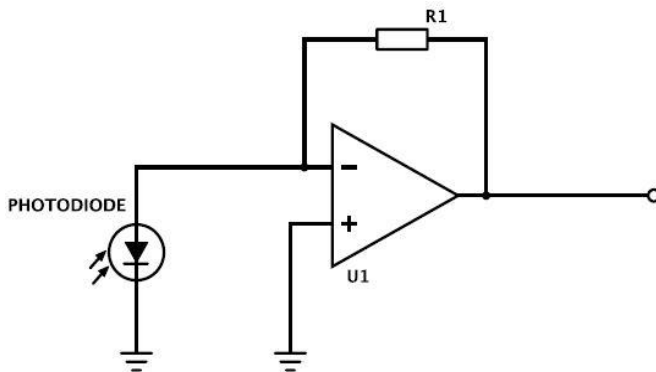

PD used in a photoconductive mode (under reverse bias)

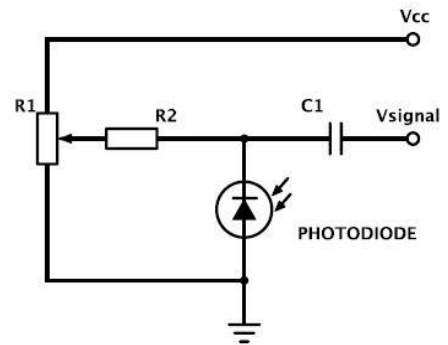

We recommend using **photovoltaic mode**, when PD is used under no reverse bias.
Use photoconductive mode (mode with reverse bias) with caution.

IMPORTANT CAUTIONS:

- please check your connection circuit before turning on the PD;
- please mind the PD polarity: PD anode is marked with a RED dot;
- please do not connect the PD to the multimeter.

Technical Drawings

Lms24PD-05

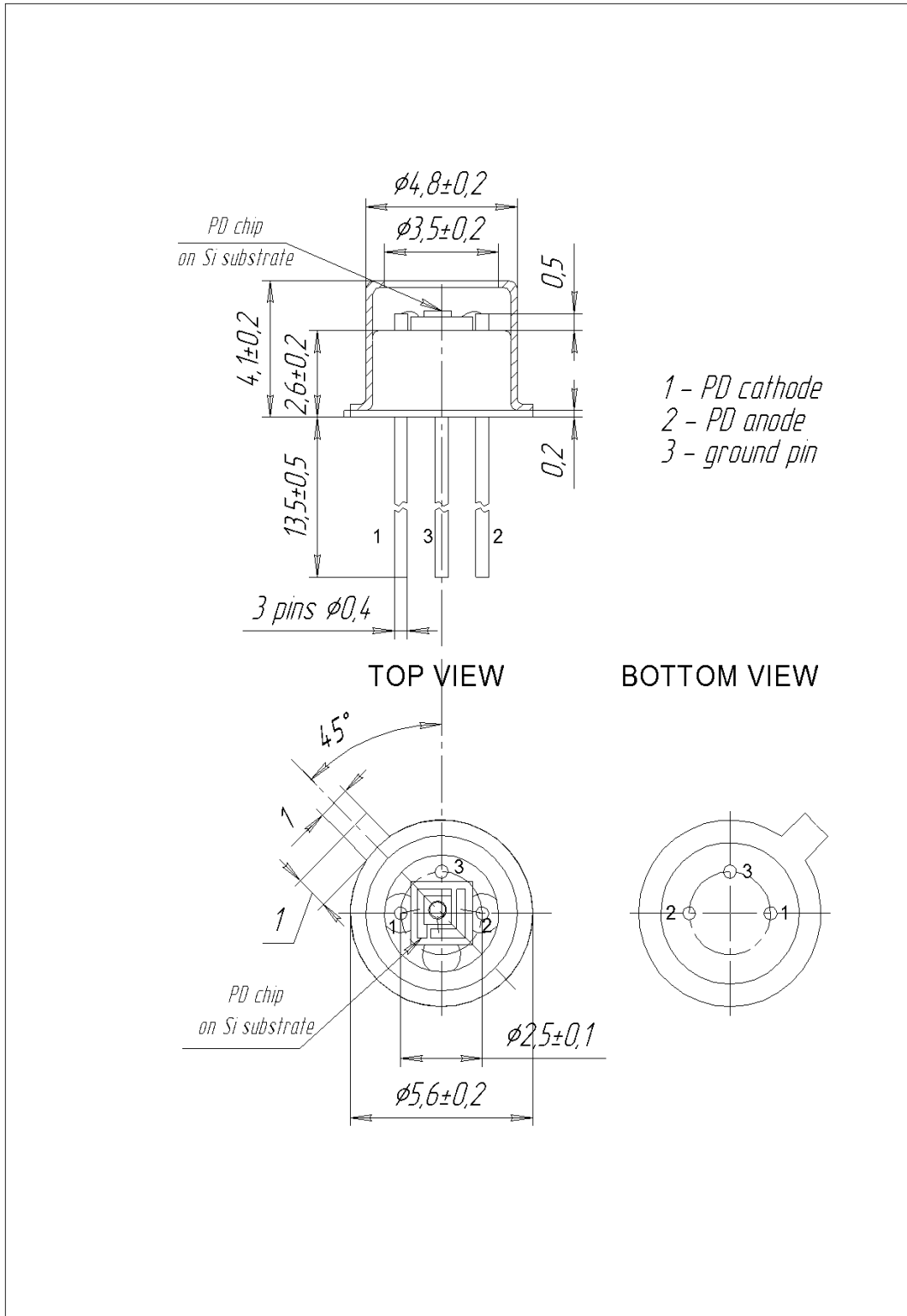

Technical Drawings

Lms24PD-05-R

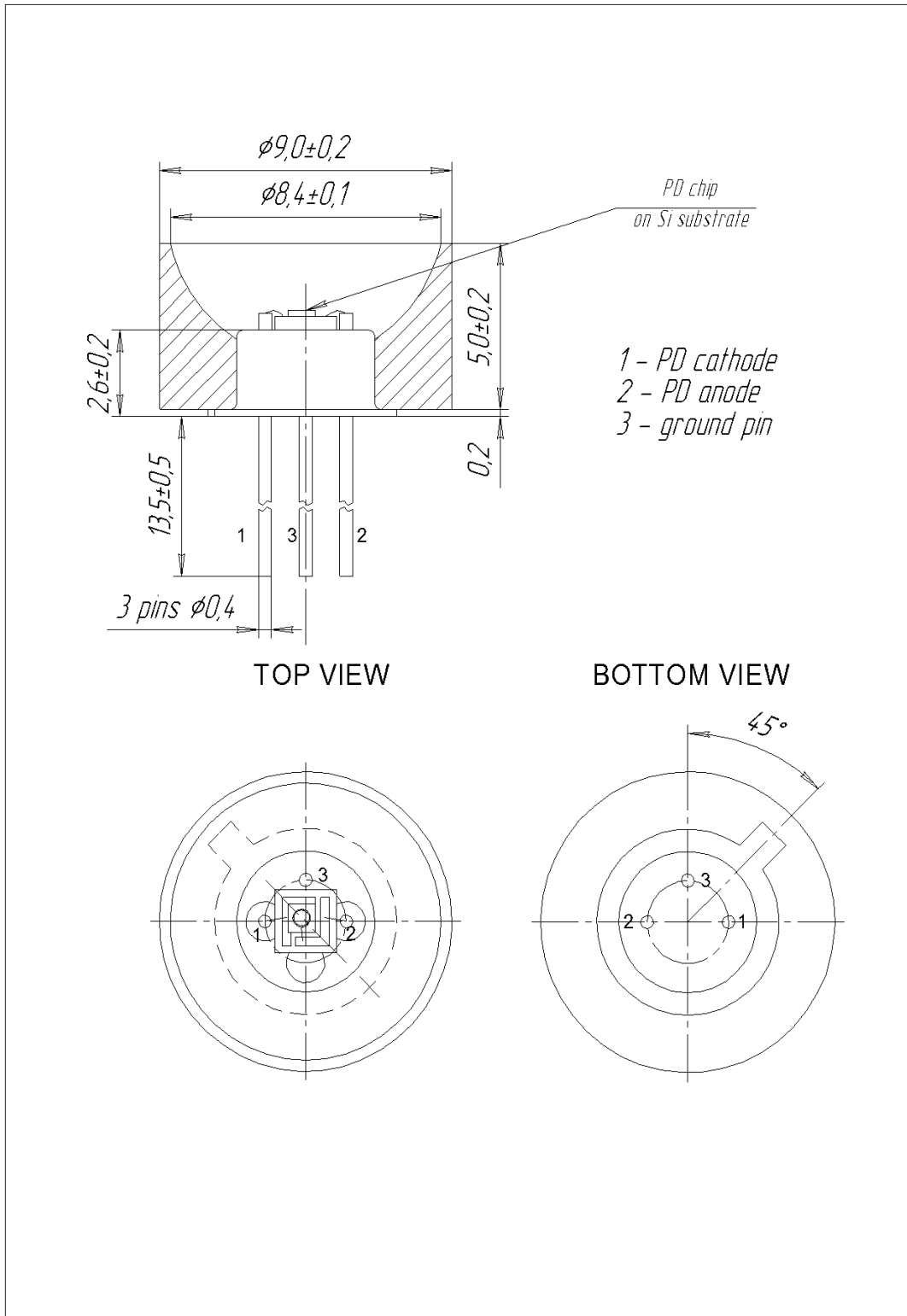

Technical Drawings

Lms24PD-05-RW

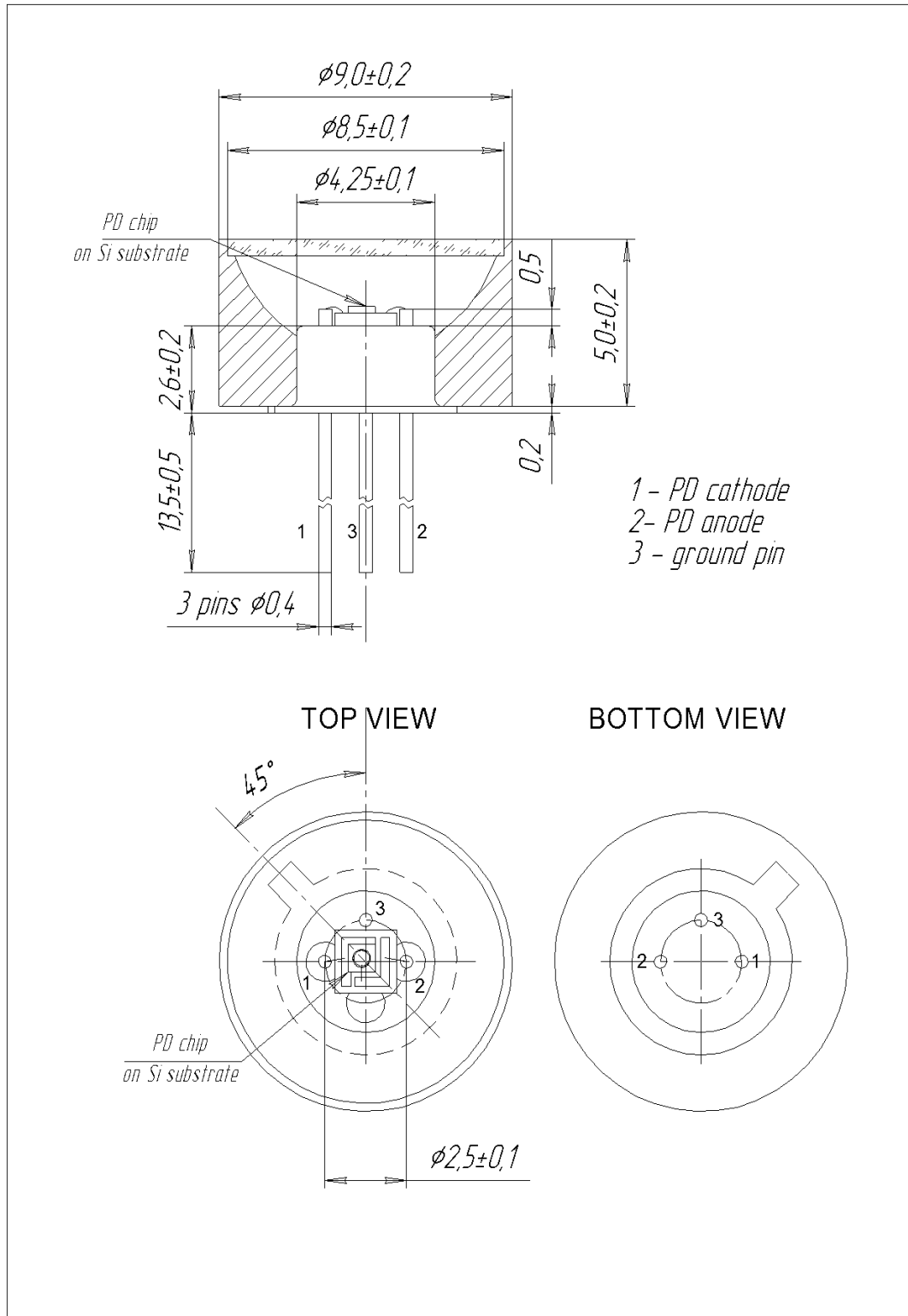

Technical Drawings

Lms24PD-05-TEM

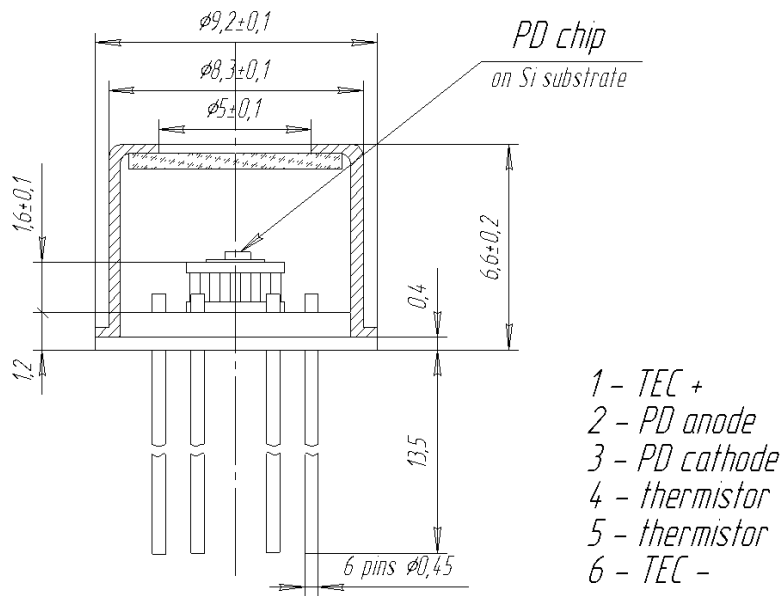

TOP VIEW

BOTTOM VIEW

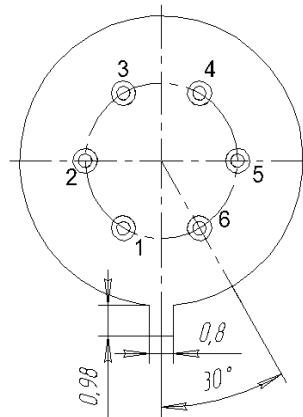
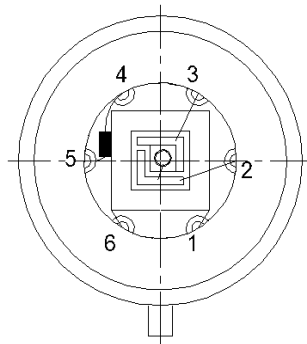

Technical Drawings

Lms24PD-05-TEM-R

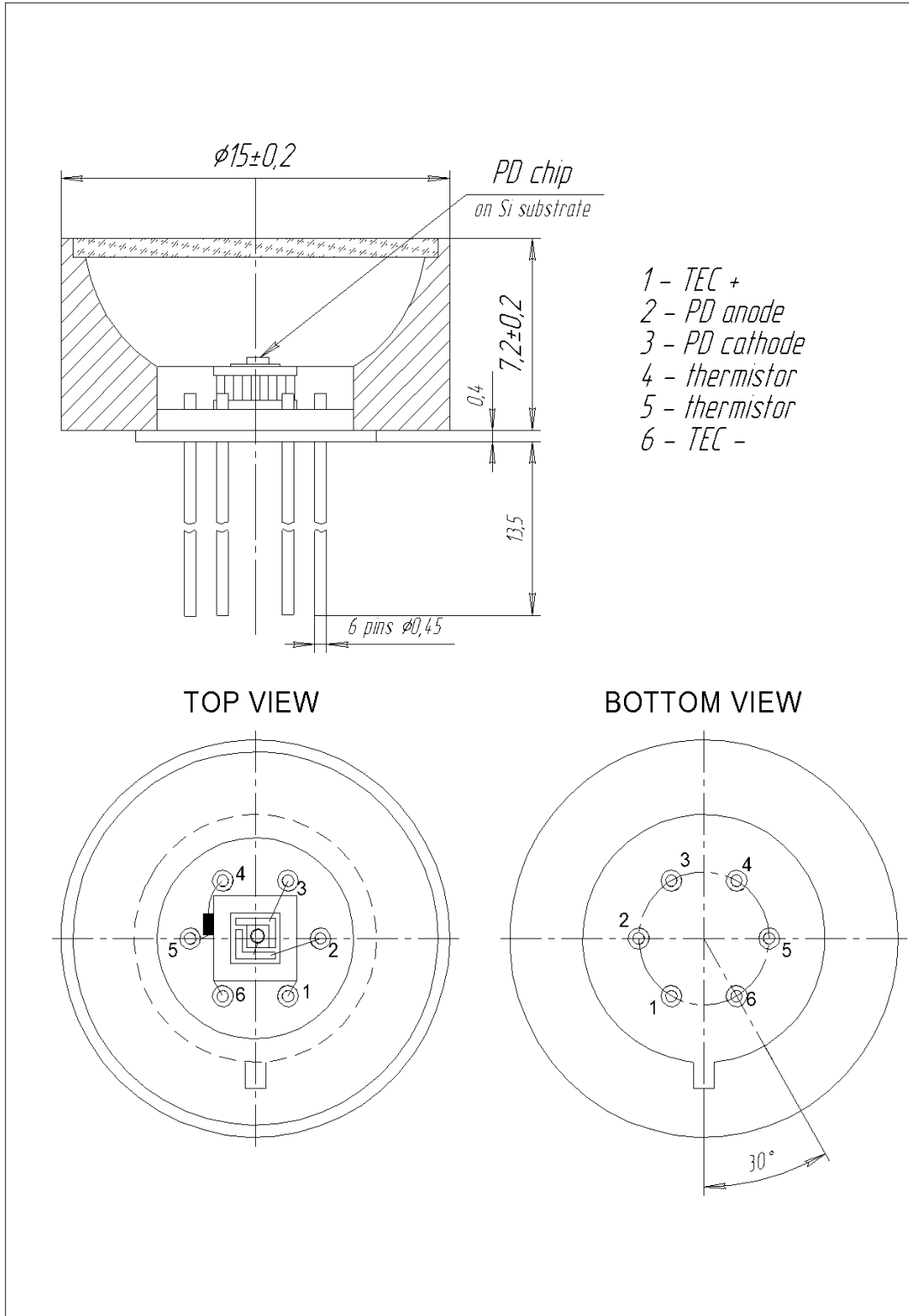

Technical Drawings

Lms24PD-05-R-PA

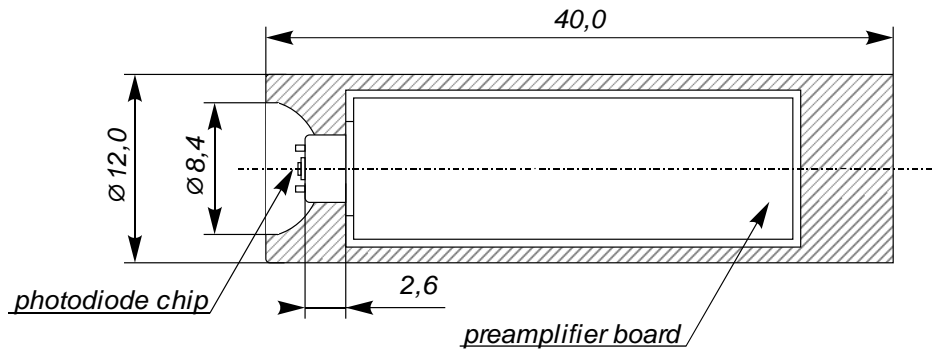

Lms24PD-05-RW-PA

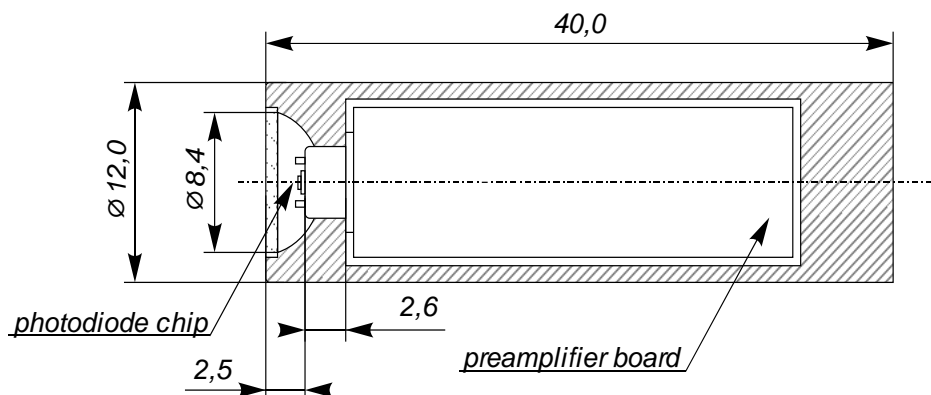

Power input voltage: +5 V, stabilized;

Connections:

The output of PD with a built-in preamplifier has four wires:

- "+" power input (to the "+" of the power output terminal block of the SDM synchronous detector);
- "-" power input (to the "-" of the power output terminal block of the SDM synchronous detector);
- output photodiode signal (to the "-" of the signal input terminal block of the SDM synchronous detector);
- output photodiode signal (to the "+" of the signal input terminal block of the SDM synchronous detector).

For the proper connection mind colours of the wires pointed in the technical data provided with the photodiode.

Related products:

- **LEDs** - sources of mid-infrared radiation;
- **SDM** - synchronous detector for PD models with preamplifiers - Lms MIR PD-XX-R-PA and Lms MIR PD-XX-RW-PA. SDM synchronous detector measures the voltage signal from the output of photodiode preamplifier and converts it to the DC voltage signal proportional to amplitude of voltage from input.