

ANT-20G Series nano Motion Technology

Direct Drive, High-Performance Goniometers

Noncontact, non-cogging, frictionless direct-drive for zero backlash or hysteresis

High speed (150°/s)

High resolution (0.05 arc second)

Excellent in-position stability

Large angular range; 20° of travel

Orthogonal mounting of two cradles provides rotation about the same point

No maintenance

Compact design



Clockwise from upper left: ANT-20G-50 mounted in an orthogonal configuration with an ANT-20G-90, ANT-20G-110, and an ANT-20G-160.

U.S. Patent No. 6,442,851

Aerotech's ANT-20G goniometers represent a significant breakthrough in the high-accuracy angular alignment of components. This unique design utilizes Aerotech's best-in-class direct-drive noncontact motor technology. When used with Aerotech's controllers, the ANT-20G series provides an industry-leading positioning speed of 150 degrees per second.

High-precision bearings, direct on-axis encoder feedback, and noncontact and noncogging direct-drive technology assure the highest level of performance and make excellent repeatability and in-position stability a reality. The goniometer cradles can be mounted orthogonally to provide pitch and roll about the same point in space. Combining this with a rotary stage under the orthogonal assembly adds a third rotation axis (pitch, roll, yaw) through the same point.

The critical elements of the ANT-20G goniometers, as with all other ANT series nanopositioners, were selected to operate in a 24/7 manufacturing environment. Unlike worm- or piezo-driven goniometers, the ANT-20G series will not require periodic adjustment or maintenance. This will assure many years of trouble-free operation. The ANT-20G cradles are available in four sizes.

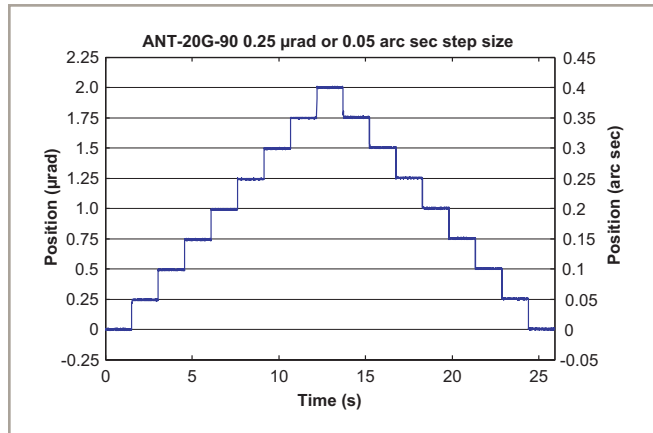

ANT-20G-90 step plot. Best-in-class resolution and exceptional in-position stability for large angular travel stages.

ANT-20G Series SPECIFICATIONS

Mechanical Specifications		ANT-20G-50	ANT-20G-90
Travel Range		20°	20°
Accuracy ⁽¹⁾		±90 µrad (±18 arc sec)	±50 µrad (±10 arc sec)
Resolution		0.25 µrad (0.05 arc sec)	0.25 µrad (0.05 arc sec)
Repeatability (Bi-Directional) ⁽¹⁾		±18 µrad (±4 arc-sec)	±10 µrad (±2 arc-sec)
Repeatability (Uni-Directional) ⁽¹⁾		±5 µrad (±1 arc-sec)	±5 µrad (±1 arc-sec)
Tilt Error Motion		±90 µrad (±18 arc sec)	±50 µrad (±10 arc sec)
Maximum Speed		150 degrees per second	
Maximum Acceleration		1200 rad/s ²	500 rad/s ²
Settling Time		See graph for typical performance	
In-Position Stability ⁽²⁾		±0.4 µrad (±0.08 arc sec)	±0.2 µrad (±0.04 arc sec)
Nominal Radius of Rotation		50 mm	90 mm
Height from Tabletop to Rotation Point		19.1 mm	57.5 mm
Maximum Torque (Continuous)		0.40 N-m	0.85 N-m
Load Capacity	Axial	1.5 kg	2.0 kg
	Moment	60 kg-mm	80 kg-mm
Stage Mass		0.55 kg (1.2 lb)	1.1 kg (2.4 lb)
Material		Aluminum	
MTBF (Mean Time Between Failure)		30,000 Hours	

Notes:

1. Certified with each stage.
2. In-Position Jitter listing is 3σ value.
3. Specifications are for single-axis systems measured at the rotation point. Performance of multi-axis systems is payload and workpoint dependent. Consult factory for multi-axis or non-standard applications.

Mechanical Specifications		ANT-20G-110	ANT-20G-160
Travel Range		20°	20°
Accuracy ⁽¹⁾		±40 µrad (±8 arc sec)	±30 µrad (±6 arc sec)
Resolution		0.25 µrad (0.05 arc sec)	0.25 µrad (0.05 arc sec)
Repeatability (Bi-Directional) ⁽¹⁾		±10 µrad (±2 arc-sec)	±10 µrad (±2 arc-sec)
Repeatability (Uni-Directional) ⁽¹⁾		±5 µrad (±1 arc-sec)	±5 µrad (±1 arc-sec)
Tilt Error Motion		±40 µrad (±8 arc sec)	±30 µrad (±6 arc sec)
Maximum Speed		150 degrees per second	
Maximum Acceleration		375 rad/s ²	250 rad/s ²
Settling Time		See graph for typical performance	
In-Position Stability ⁽²⁾		±0.2 µrad (±0.04 arc sec)	±0.15 µrad (±0.03 arc sec)
Nominal Radius of Rotation		110 mm	160 mm
Height from Tabletop to Rotation Point		76.2 mm	120.4 mm
Maximum Torque (Continuous)		1.00 N-m	2.40 N-m
Load Capacity	Axial	2.0 kg	3.5 kg
	Moment	80 kg-mm	140 kg-mm
Stage Mass		1.2 kg (2.6 lb)	1.6 kg (3.5 lb)
Material		Aluminum	
MTBF (Mean Time Between Failure)		30,000 Hours	

Notes:

1. Certified with each stage.
2. In-Position Jitter listing is 3σ value.
3. Specifications are for single-axis systems measured at the rotation point. Performance of multi-axis systems is payload and workpoint dependent. Consult factory for multi-axis or non-standard applications.

ANT-20G Series SPECIFICATIONS

Electrical Specifications	ANT-20G-50	ANT-20G-90	ANT-20G-110	ANT-20G-160
Drive System	Slotless, Brushless, Direct-Drive			
Feedback	Noncontact Encoder			
Maximum Bus Voltage	±40 VDC			
Limit Switches	5 V, Normally Closed			
Home Switch	Near Center			

Recommended Controller	ANT-20G-50	ANT-20G-90	ANT-20G-110	ANT-20G-160
Multi-Axis	A3200	Npaq-MXR Npaq MR-MXH Ndrive ML-MXH		
	Ensemble	Epaq-MXH Epaq MR-MXH Ensemble ML-MXH		
Single Axis	Soloist	Soloist ML-MXH		

Notes:

1. Linear amplifiers are required to achieve the listed specifications. Other options are available.

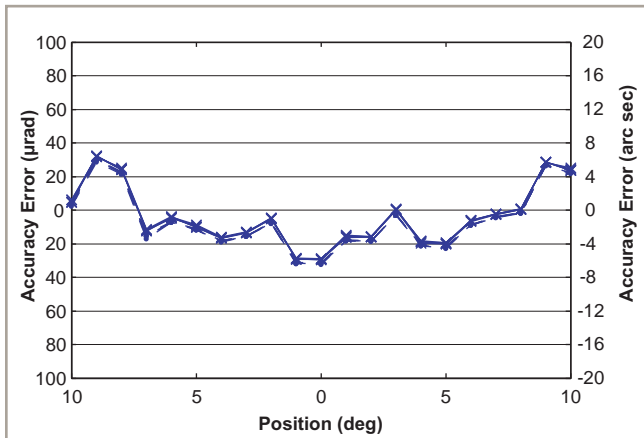

ANT-20G-90 accuracy, five runs, bi-directional, uncalibrated, shows the high level of system accuracy.

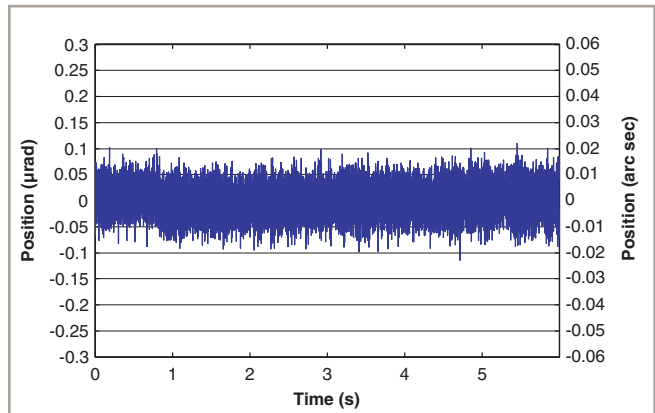

ANT-20G-90 in-position stability. Excellent in-position stability is another feature of the ANT Series goniometers.

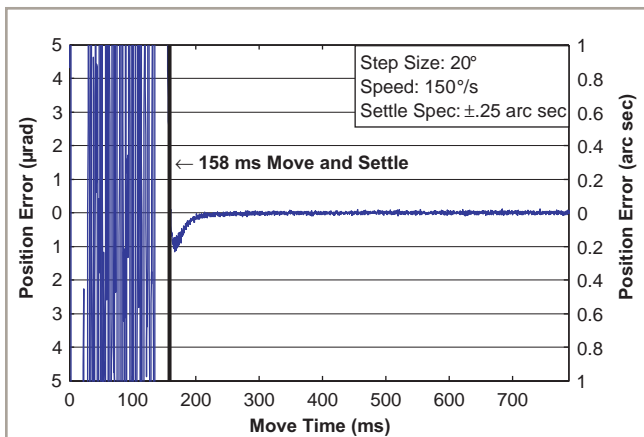

ANT-20G-90 step and settle performance. Outstanding settling time enhances throughput of most applications.

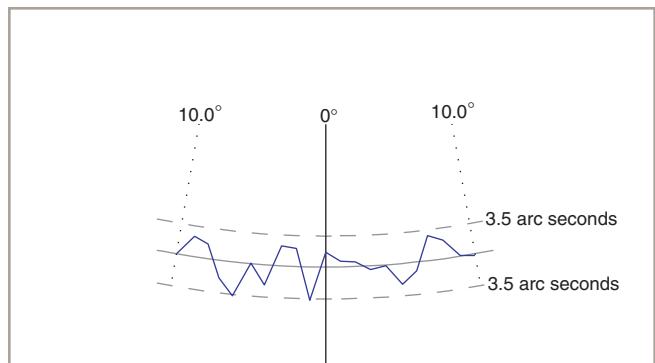

ANT-20G-90 tilt error motion performance.

ANT-20G Series DIMENSIONS

ANT-20G-50

U.S. Patent No. 6,442,851

All stages shown at center of travel.

Mounting surface quality: Flatness = 5 μm [0.0002 in.]

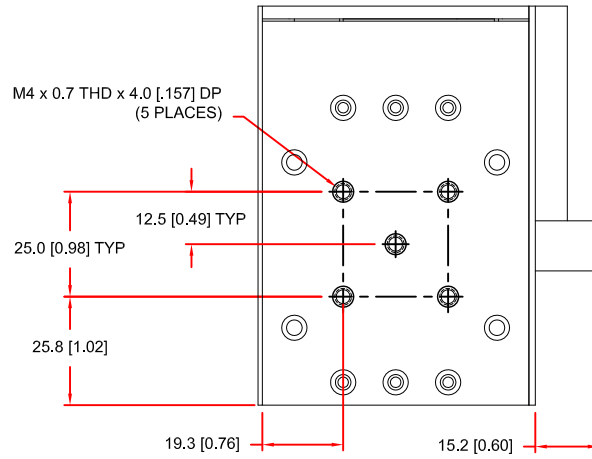

DIMENSIONS - MILLIMETERS [INCHES]

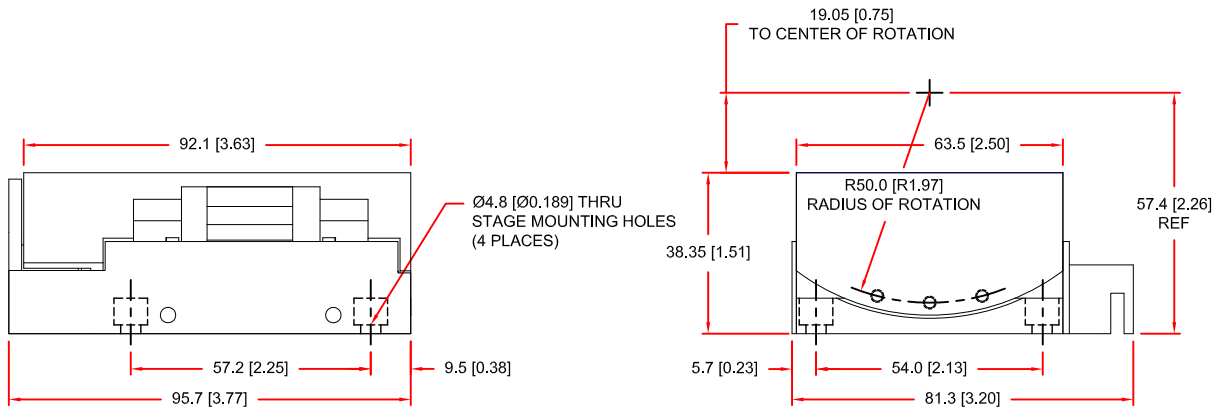

ANT-20G Series DIMENSIONS

ANT-20G-90

U.S. Patent No. 6,442,851

All stages shown at center of travel.

Mounting surface quality: Flatness = 5 μm [0.0002 in.]

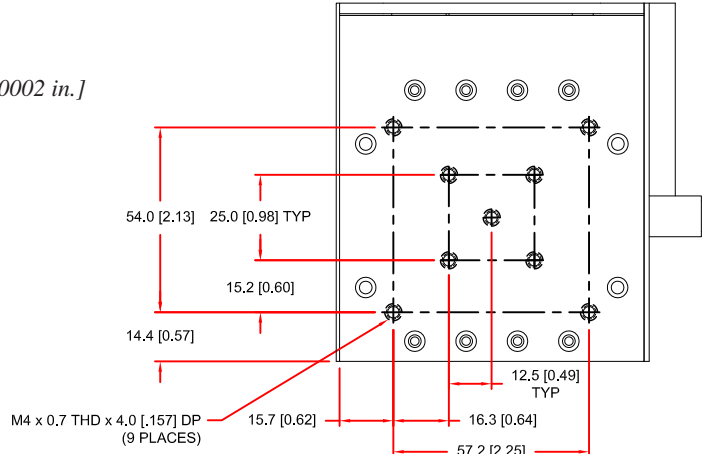

DIMENSIONS - MILLIMETERS [INCHES]

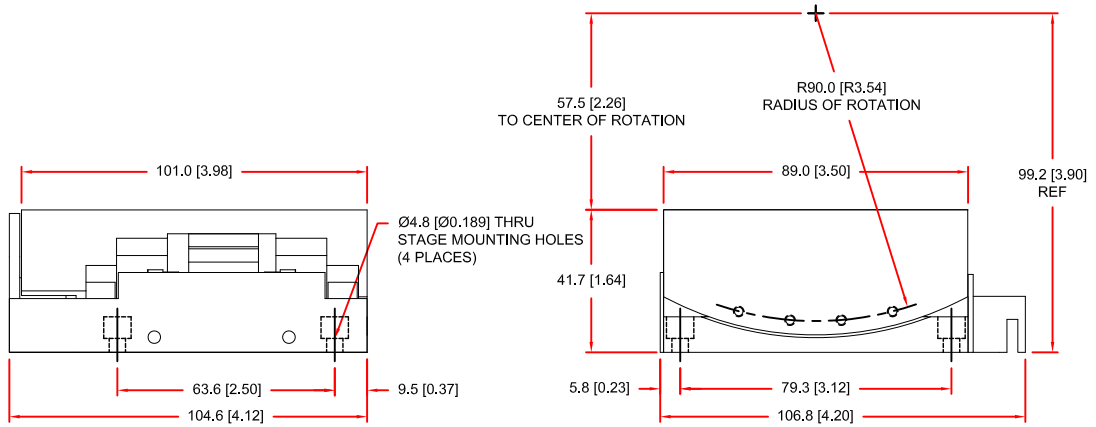

ANT-20G-50-90

ANT-20G-50/90

SEE ANT-20G-50 FOR TABLETOP DIMENSIONS

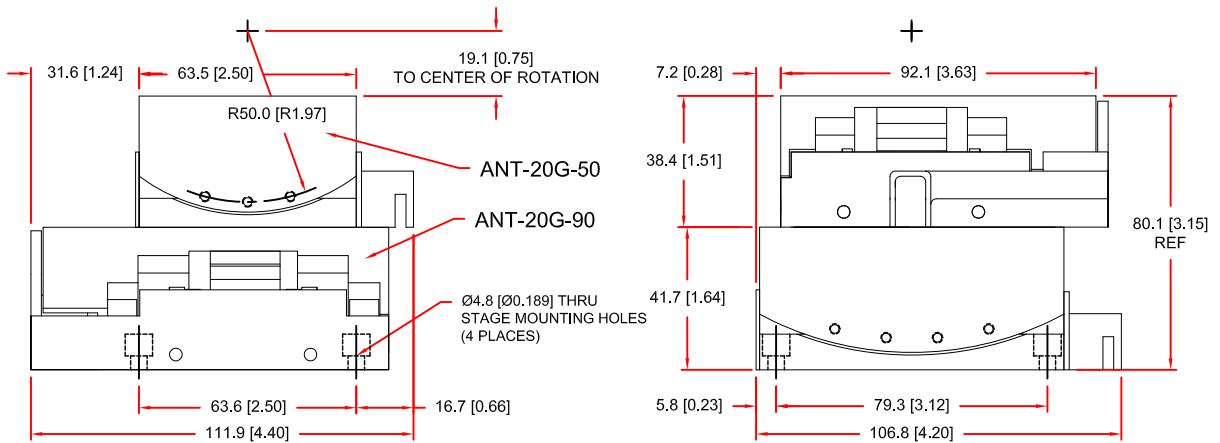

U.S. Patent No. 6,442,851

All stages shown at center of travel. Mounting surface quality: Flatness = 5 μm [0.0002 in.]

ANT-20G Series DIMENSIONS

ANT-20G-110

U.S. Patent No. 6,442,851

All stages shown at center of travel.

Mounting surface quality: Flatness = 5 μm [0.0002 in.]

M4 x 0.7 THD x 4.0 [1.57] DP
(5 PLACES)

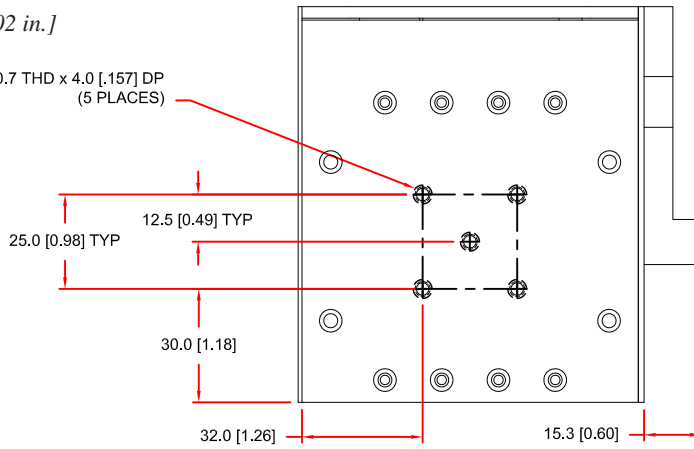

DIMENSIONS - MILLIMETERS [INCHES]

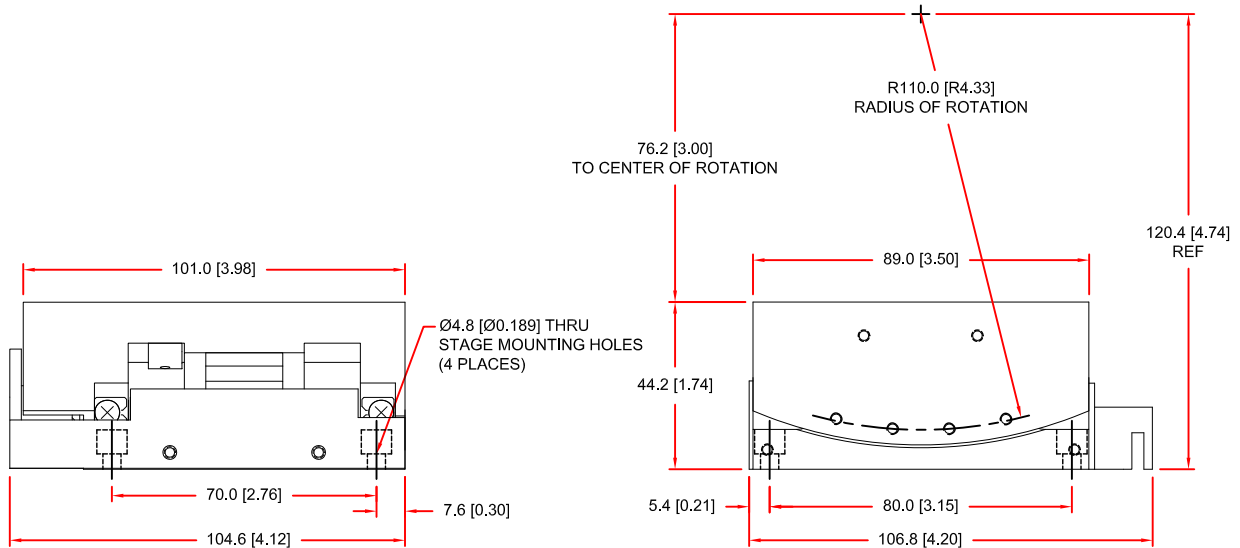

ANT-20G Series ORDERING INFORMATION

Ordering Example

ANT-20G	50		-M
Series	Radius of Rotation (mm)	Stage Construction Options	Mounting and Grid Pattern
	50	/VAC3	-M
	90	/VAC6	
	110		
	160		

Ordering Information

ANT-20G-50	20 degree travel goniometer with proprietary direct-drive motor technology, 50 mm radius of rotation, limits, 1 Vpp sinusoidal encoder, 1 meter cable, 25 D connector
ANT-20G-90	20 degree travel goniometer with proprietary direct-drive motor technology, 90 mm radius of rotation, limits, 1 Vpp sinusoidal encoder, 1 meter cable, 25 D connector
ANT-20G-110	20 degree travel goniometer with proprietary direct-drive motor technology, 110 mm radius of rotation, limits, 1 Vpp sinusoidal encoder, 1 meter cable, 25 D connector
ANT-20G-160	20 degree travel goniometer with proprietary direct-drive motor technology, 160 mm radius of rotation, limits, 1 Vpp sinusoidal encoder, 1 meter cable, 25 D connector

Stage Construction Options

/VAC3	Vacuum preparation to 10 ⁻³ torr
/VAC6	Vacuum preparation to 10 ⁻⁶ torr

Accessories

ALIGNMENT-PA10	10 arc sec orthogonal
ALIGNMENT-PA5	5 arc sec orthogonal